

# International Journal of Engineering Sciences & Research Technology

(A Peer Reviewed Online Journal)  
Impact Factor: 5.164



**Chief Editor**  
**Dr. J.B. Helonde**

**Executive Editor**  
**Mr. Somil Mayur Shah**

**ABSTRACT**

Nowadays women are less secure and their security is the major issue. They have to undergo various difficult conditions and have to prove themselves every time in all critical conditions. So for their security and safety, government has provided security through rules and regulations to the society. Although there are many existing systems for security purpose, requirement of advanced system is arising. In order to overcome such problems smart security system for women is implemented. This paper describes safe and secured electronic system for women which comprises of an arduino controller and sensors such as temperature sensor, sweat sensor pulse rate sensor, GSM and GPS. When the women is in threat, the device senses the body parameters like heart beat rate , change in temperature and sweat rate. When the sensor crosses the threshold limit, the device gets activated and traces the location of the victim using GPS and also the buzzer will alert the surroundings. By using GSM module, the victim's location is send to the registered contact numbers. The system also consists of a shock generation mechanism to produce non lethal electric shock in emergency situations to defend the attacker.

**KEYWORDS:** Women Safety , Arduino controllers , GPS module , GSM module , Shock generation , Buzzer.

**1. INTRODUCTION**

The system comprises of sections which describes a quick responding, cost protection system for an individual and especially for women using which a women in distress can help by sensing the body parameters. Self Defense System for victim is like a smart watch. It has the ability to help women with technologies that are embedded in a compact device[1].

The women wearing this device as a watch or band , in case of any harassment the device senses the body parameter like temperature, pulse rate and if it reaches the threshold condition, location information is send as SMS alert to a few predefined emergency numbers following a blank call and soon help is on its way! .There is a chance the system will consist of embedded hardware and software co designed for this dedicated application[2]. The system allows for knowing exact location of the individual. By providing the instant location of the distressed victim to the police so that the incident would be prevented and the suspect apprehended.

In case if the care taker wants to know the present location of the victim, he/she can do so by sending an SMS to the SIM number of the victim which contains a secret password. Then system respond to such request by sending back an SMS containing location information in terms of Latitude and Longitude. This helps to reduce crime against women. It also contains a shock generation mechanism to produce non lethal electric shock in emergency situations to defend the attacker[3].

The module composed of sub modules namely:

- **Sensing Module:** I am OK button, pulse rate sensor.
- **Control Module:** Atmega 328 microcontroller, power supply unit.
- **Transmission Module:** LCD Module, GSM Module, GPS Module.

**2. MATERIALS AND METHODS**

## 2.1 Block diagram

Aim of the proposed algorithm is to help victim by the technologies that are embedded in it. When the supply is given the device will get initialized. GPS and GSM connected to ARDUINO also start working. The system is proposed as three parts:

- Wearable Part
- Remote Part
- Shock Generation

### 2.1.1 Wearable Part

This part consists of Arduino Nano , Sensors , RF module and I am OK button .

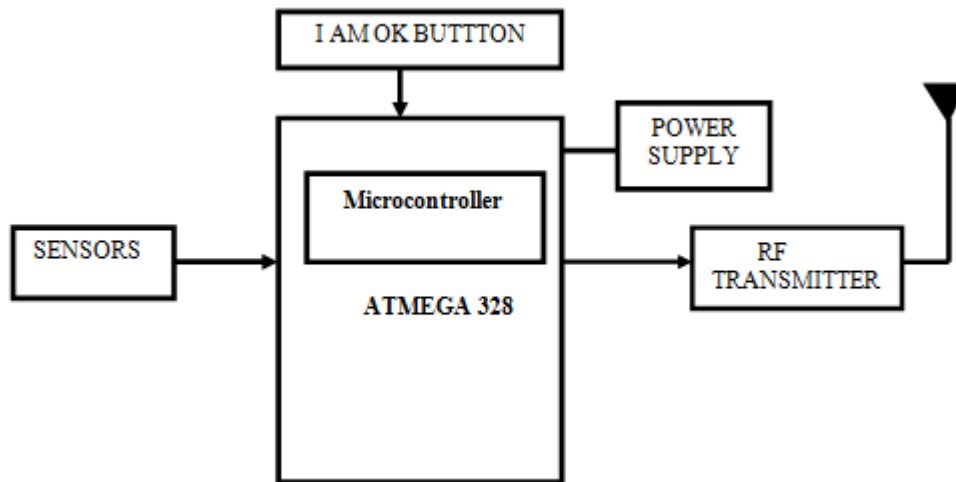

Figure 2.1

When the victim is in danger the device senses body parameters of the victim including heart rate and temperature and if it reaches the threshold condition, the kit displays emergency situation and it produces an alarm to alert the surroundings[4]. The threshold value will be initially stored in the controller and each sensed value will be compared with the stored value, if any alteration occurs a coded signal is sent to the remote part via a wireless communication, RF transmission. In any case if the victim does not need a help she can press the I'm OK button then the alerting messages does not delivered even though the parameters exceeds the threshold value[5,6].

### 2.1.2 Remote Part

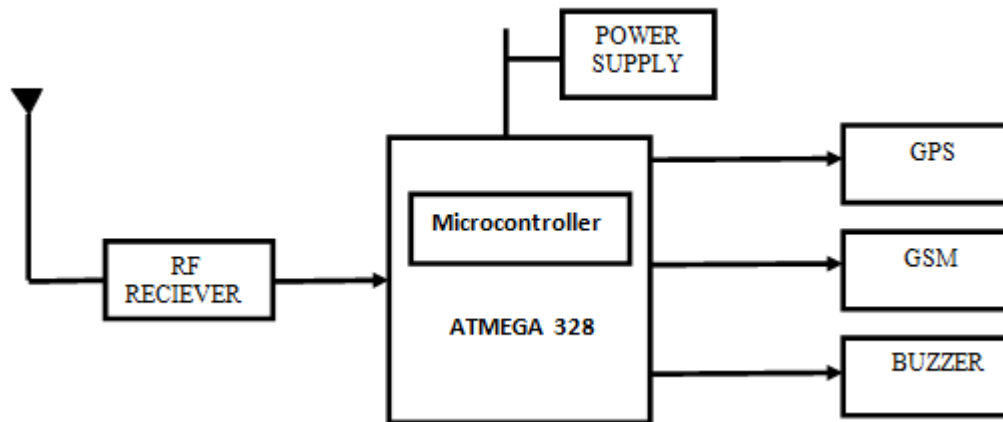

Figure 2.2

When the coded signal from the wearable part is received, the received data from GPS will be read by the controller, latitude and longitude coordinates are filtered. The GSM will send these coordinate along with an alert message followed by a blank call to the predefined numbers. And an alarm will produced. If a message like TRACK is sent by someone to the GSM number it provides the current location of the victim[6].

2.1.3 Shock Generation Circuit

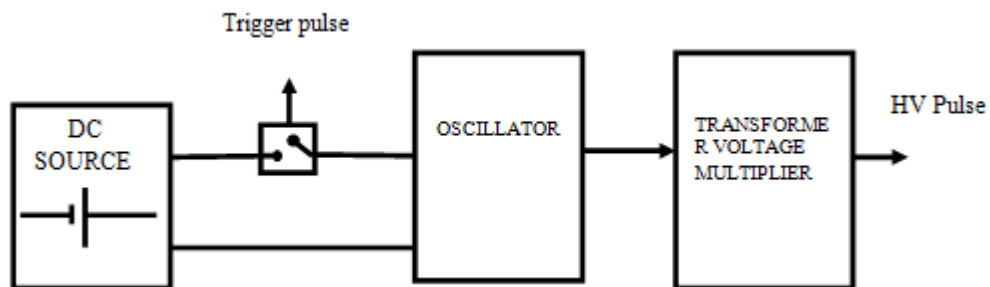
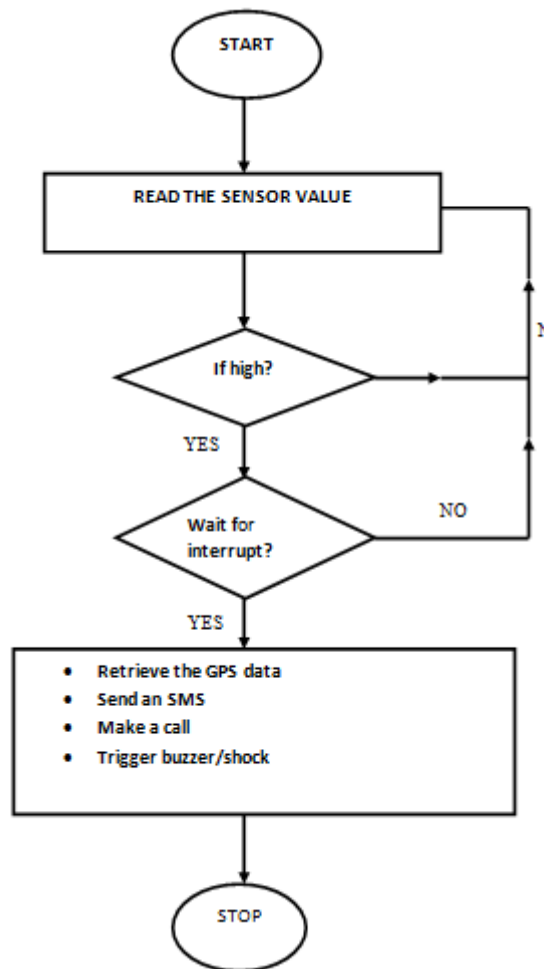

Figure 2.3

The switched ON voltage from the battery is applied to the next oscillator stage comprising a transistor T1/transistor T2 coupled oscillator configuration. The transformer steps-up the oscillating frequency at its secondary winding and functions like a smaller version of an inverter. The stepped-up AC at the output of the transformer is again boosted up through a diode/capacitor ladder network. The boosted voltage ranging several thousand volts gets stored inside an output AC capacitor across the output and becomes ready to “shoot”[7].

2.2 Flow chart



**2.3 Results and discussion**

When the pulse rate sensor value is in between 60 and 100 beats/sec ; it is considered to be normal condition . When the sensor value is below 60 beats/sec , it is considered as unconscious state and the alert message following a blank call will send .When the sensor value exceeds 100 beats/sec , it is considered to be tensed state , then also an alert message followed by a blank call is send .In both conditions of sending message ,a buzzer alarm will produced .

**Tables:**

*Table 2.1: Sensor Value and Conditions*

PULSE RATE SENSOR VALUE	CONDITION	OUTPUT
Below 60 beats/sec	Unconscious	Message will sent
60-100 beats/sec	Normal	Message will not sent
Above 100 beats/sec	Tensed	Message will sent

**3. CONCLUSION**



Through study and analysis, the women safety using GPS tracking system was studied. This system which uses GPS and GSM technologies will be very much useful to women, whenever they went outside alone. This system also provides defensive measures like shock[8]. The major advantage of the proposed system is that even the victim become unconscious the system will not deactivated and no need for pressing a button for seeking help. It is practically possible and economically comfort to use.

#### 4. ACKNOWLEDGEMENT

We would like to express our gratitude to all the teaching and non-teaching staffs of **College of Engineering, Karunagappally** for their whole hearted support and for providing us with the necessary infrastructure. We also like to express my sincere thanks to **Dr.Jaya.V.L**, The Principal of the college for her kind support for the progress of our project work. Special thanks to the Head of The Electronics and Communication Department, **Dr. Gopakumar.C** for all the proper guidance and encouragement and also we thank to our Advisor **Mrs.Deepa T R** for her proper guidance and support. We take this opportunity to thank KSCSTE (Kerala State Council for Science , Technology and Development) for allotting fund for our project work. Last but not the least I am grateful to my friends and parents for their valuable support and motivation.

#### REFERENCES

- [1] R. George, A. Cherian., A. Antony, H. Sebestian, M. Antony, B.T.Rosemary An Intelligent Security System for Violence against Women in Public Places, International Journal of Engineering and Advanced Technology (IJEAT) ISSN: 2249 – 8958, Volume-3, Issue-4, April 2014.
- [2] S. Sangeetha, P. Radhika, Application for Women Safety, IOSR Journal of Computer Engineering (IOSR-JCE), Volume 17, Issue 3, Ver. IV (May – Jun. 2015), PP 01-04.
- [3] E. Peter, Andrew, and B Paul, S. Matt, H .Jason, P. Carlos, and M Scarlett. Designing Public Safety Mobile Applications for Disconnected, Interrupted and Low Bandwidth Communication Environments. IEEE. 10 (978-1-4799-1535-4/13), p790-796(2013)
- [4] Dr. Sridhar Mandapati, SravyaPamidi, SriharithaAmbati “A Mobile Based Women Safety Application(I Safe Apps)”, IOSR-JCE, eISSN:2278-0661, p-ISSN:2278-8727, Volume 17,Issue 1, VerI(Jan-Feb.2015), PP 29-34.
- [5] B.Vijaylakshmi, Renuka.S, PoojaChennur, Sharangowda.Patil “SELF DEFENSE SYSTEM FOR WOMEN SAFETY WITH LOCATION TRACKING AND SMS ALERTING THROUGH GSM NETWORK”. IJRET,eISSN:2319-1163|pISSN:2321-7308
- [6] NishantBhardwaj,NitishAggarwal “Design and Development of „Suraksha“-A Women safety Device”. IJICT,ISSN:0974-2239, Volume 4, No.8(2014), pp.787-792. It will get done by IJESRT Team
- [7] H. A. Abdallah Dafallah “DESIGN AND IMPLEMENTATION OF AN ACCURATE REAL TIME GPS TRACKING SYSTEM” in e-Technologies and Networks for Development (ICEND), 2014 Third International Conference.
- [8] AbhijeetTekawade, Ahmed Tutake, RavindraShinde, Pranay Dhole, “Mobile Tracking Application for Locating Friends Using LBS”, International journal Innovative research in computer and communication engineering, vol: 1, Issue: 2, April 2013.